



CRANLEIGH MEMORIALS

BEAUTIFULLY CRAFTED MEMORIALS

Memorial Brochure

www.cranleighmemorials.com

The Loving Remembrance
OF

ELI HAMSHIRE

OF GADBRIDGE LODGE, EWHURST
WHO DEPARTED THIS LIFE
OCTOBER 10th AND WAS INTERRED
HERE OCTOBER 14th 1896
AGED 61 YEARS

A SINCERE KIND FRIEND AND
AFFECTIONATE FATHER WHO
FELL TO SLEEP IN JESUS

THE WISH OF A WAYFARING MAN
MY HEARTY WISH TO YOU IS THAT
A SUPREME POWER MAY EVER REIGN OVER
YOU AND THAT THE SUN OF GLORY MAY
EVER SHINE AROUND YOU AND THAT THE
GATES OF PARADISE WILL BE OPENED
UNTO YOU, TO THE HIGHEST DESIRE OF
TRUE HAPPINESS

Creating beautiful memorials since 1976

Our aim is simple - to supply the best quality memorials and provide the highest level of customer service.

The range of materials and designs has greatly increased over the years and we are able to supply a vast choice of headstones and memorials for cemeteries, crematoria and churchyards.

We are also specialists in maintenance and renovation and have proven experience of restoring memorials back to their original condition.

The quality of materials and the level of service we provide does not come at an

Memorials should be unique to reflect the people they commemorate.

We are so confident in the quality of materials used that we offer a unique 50 year material guarantee.

our unrivalled level of care has been recognised by customer service awards and we are full members of the National Association of Monumental Masons (NAMM)

Granite Lawn

Granite Lawn Headstones are designed for a lawn section in a cemetery where only a headstone and base are allowed.



CM01

Ogee shaped headstone with a cross and rose design. The base has a vase which sits beside the headstone.

This example is shown in all Polished Black Granite.

The vast majority of memorials are now made from granite. It is virtually everlasting, maintenance free and available in a wide range of colours.

All memorial designs are available in a range of colours and materials, see page 50 - 51 for further details.



CM02

Bronze praying hands decorate the top corner of this memorial. The chamfered base has two holes for flower containers.

The example above is shown in Black Granite.



CM03

Shown with silver praying hands which are optional. The base has a centre hole for a flower container. The example above is shown in Blue Pearl Granite.



CM04

All Polished Butterfly Blue Granite with polished rebates which run down each side of this memorial. The base has one centre hole for a flower container.

The example above is shown in Butterfly Blue Granite.



CM05

A rounded top with ogee shoulders. The shaped base comes with a hole in each corner for a flower container. This rich green granite has a striking maroon vein running through the material.

The example above is shown in Tropical Green Granite.



CM06

This headstone has a contrasting moulded edge. The base has a centre hole for a flower container. The example above is shown in Avon Grey Granite.



CM07

A fully polished moulding on both headstone and base in this delicate pink granite.

The example above is shown in Xiamen Pink Granite.

Granite Lawn



CM08

This has a scroll on the face for an inscription. The base has a hole for a flower container.

The example is shown in Black Granite.



CM09

A polished moulding adds emphasis to the inscription area. The base comes with a centre hole for a flower container.

The example above is shown in Dark Grey Granite.



CM10

A sandblast etched rose in each corner and a double border. The base has a centre hole for a flower container.

The example above is shown in Dark Grey Granite.



CM11

This gives fine contrast to the delicate white rose with the elegant pin line. The base has a centre hole for a flower container.

The example above is shown in Flint Grey Granite.



CM12

The rose design in each corner of the shoulder is highlighted with pure gold leaf. The base has a centre hole for a flower container.

The example above is shown in Dark Grey Granite.



CM13

The area above the inscription is recessed leaving a central raised heart with colour painted violets. The base has a hole in each corner for a flower container.

The example above is shown in Black Granite.



CM14

A traditional shaped top. The base comes with a centre hole for a flower container.

The example above is shown in Black Granite.



CM15

Rounded top and shaped shoulders with a chamfered edge. The base comes with a centre hole for a flower container.

The example above is shown in Black Granite.



CM16

A pin line accentuates the classic lines of this memorial. Shown with a bow front base and a centre hole for a flower container.

The example above is shown in Glenaby Granite.



CM17

A scotia shoulder shaped headstone with a base to match. The base has a centre hole for a flower container.

The example above is shown in Steel Grey Granite.

Granite Lawn



CM18

This is an unusual variation on the more common Blue Pearl. A Gothic shaped headstone with an optional bronze dove.

The base has a centre hole for a flower container. The example above is shown in Emerald Pearl Granite.



CM19

Skilled craftsmen have etched a depiction of the 'Last Supper' (Any design can be specified). The base has a centre hole for a flower container.

The example above is shown in Black Granite.



CM20

Half ogee headstone with a stained glass window in the top left shoulder.

The example above is shown in Black Granite.



CM21

This has a star cross and rose design on the headstone. The base has a hole for a flower container.

The example above is shown in Black Granite.



CM22

Shown with a beautifully hand painted lily. Any flower can be depicted. The base comes with a hole for a flower container.

The example above is shown in Black Granite.



CM23

Shown as Black Granite. One of many beautiful hand etched scenes that can be added to any memorial (Please ask for details).

The example above is shown in Black Granite.



CM24

An offset peon top with a single rose ornament climbing up the side.
The base comes with a hole for a flower container.

The example above is shown in Black Granite.



CM25

Roses or any other flower can be included in this sandblasted panel.
The base has a hole for a flower container in each corner.

The example above is shown in Blue Pearl.



CM26

A square top headstone with a church window design. The base has a centre hole for a flower Container.

The example above is shown in Black Granite.



CM27

An ogee top headstone with a church window and bible design.
The base has a hole for a flower Container.

The example above is shown in Black Granite.



CM28

Ogee shaped headstone with the design of 'Jesus'. Any design of your choice may be added to this or any other memorial. The base has a hole for a flower container.

The example above is shown in Black Granite.



CM29

Ogee top and rounded shoulders.
The base has matching corners and a centre hole for a flower container.

The example above is shown in Ruby Red Granite.

Granite Lawn



CM30

This book shaped headstone sits on a base with two vases and a central heart token.

The example is shown in Black Granite.



CM31

Ogee shaped headstone with a carved rose and popular worked book which has a unique turned page feature.

The base has a hole for a flower container in each corner.

The example above is shown in Black Granite.



CM32

Ogee shaped headstone with sandblast roses and book design. The base has a hole in each corner for a flower container.

The example above is shown in Bahama Blue Granite.



CM33

Ogee shaped headstone with sandblast roses and book design. The base has a hole in each corner for a flower container.

The example above is shown in Dark Grey Granite.



CM34

Gates of Heaven headstone with roses design, a cross on each column and a centre hole for a flower container. The example



CM35

Gates of Heaven headstone with a border outline and a centre cross design. A straight base with a centre



CM36

Gates of Heaven headstone with roses design. There is a statue of Jesus who sits on the base with two holes for a



CM37

A classic shaped book with a cord and tassel. Shown with sandblast pages. The extra wide rest sits on a beautiful shaped base which has a centre hole for a flower container.

The example above is shown in Black Granite.



CM38

A simple elegant square shaped tablet with a sandblast book design. This has a rest which sits on a square shaped base with two holes for a flower container.

The example above is shown in Black Granite.

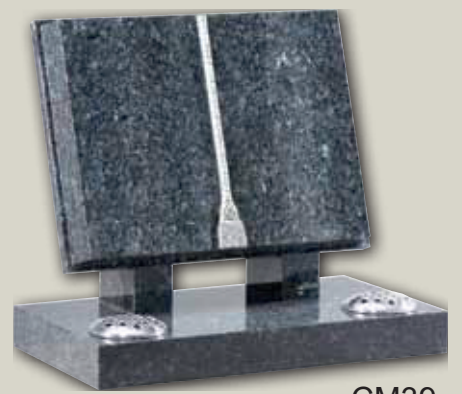

CM39

With a finely carved cord and tassel with shaped pages. This has a rest which sits on a square shaped base with two holes for a flower container.

The example above is shown in Blue Pearl Granite.

Granite Lawn



CM40

An elegantly carved angel embracing a heart. This is sitting on a square shaped base.

The example is shown in Imperial Red Granite.



CM41

A simple and classic cremation heart. The square base has a hole for a flower container in each corner.

The example above is shown in Star Galaxy Granite.



CM42

Elegant double hearts entwined, sitting on a square base which has a hole for a flower container in each corner.

The example above is shown in Ruby Red Granite.



CM43

Double heart entwined with a delicately hand carved and highlighted lily dividing the double heart. This is sitting on a square base which has a hole for a flower container in each corner.

The example above is shown in Black Granite.



CM44

A heart shaped headstone with natural carved roses. The base has a centre hole for a flower container.

The example above is shown in Black Granite.



CM45

A heart shaped headstone with shoulders. This has a design with roses which can be plain or painted in any colour. The square base has a hole for a flower container in each corner.

The example above is shown in Black Granite.



CM46

Heart shaped headstone with two swans which decorate this memorial. This is sitting on a square shaped Base.

The example above is shown in Black Granite.

Marble Lawn

Marble has been used to create memorials for centuries and is ideal for elaborate carving.

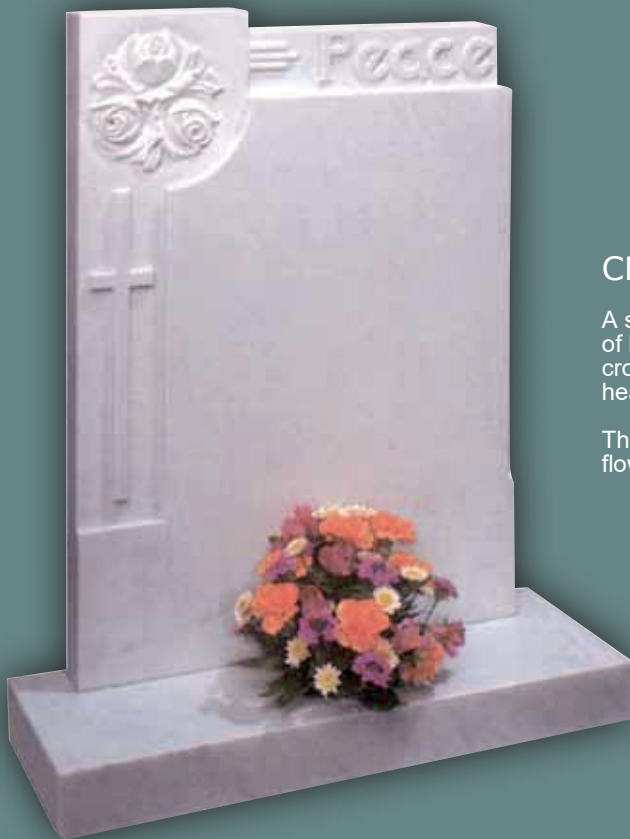

CM47

A shaped headstone with a circle of hand carved roses. A raised cross and 'Peace' gives this headstone a style of its own.

The base has a centre hole for a flower container.

All of our marble memorials are made from the finest Italian white marble. Marble is a softer stone than granite and is therefore ideal for sculpture and carving. It should be noted that marble is porous and will weather over



CM48

Ogee shape headstone with a hand carved rose in the top centre. The shaped ogee base has a centre hole for a flower container.



CM49

A shaped headstone with an inset of hand carved rosebud and leaves. The shaped base has a centre hole for a flower container.



CM50

An ogee top headstone with a dog rose carved in each corner. This is sitting on a shaped base with a centre hole for a flower container.



CM51

Ogee top headstone with two hand carved roses in a sunken panel. This is sitting on an ogee shaped base with a centre hole for a flower container.



CM52

This multi shaped top headstone has a hand carved panel. The shaped base has a centre hole for a flower container.



CM53

An elegant double scroll headstone with carved angels either side. The base has a centre hole for a flower container.



Contents

M54



CM55

A hand carved angel sitting over a hand sculptured shaped book. The base has a hole in each corner for a flower container.



CM56

A bible sitting on rests and two bases. This has a hand carved rose in the centre of the book. The bottom base has a centre hole for a flower container.



CM57

A beautifully shaped book with a hand carved dove of peace on the top right hand page. This is sitting on a shaped base with a centre hole for a flower container.



CM58

Upright headstone book with a carved cord and tassel and carved roses across the top. This is sitting on a shaped base which has one centre hole for a flower container.



CM59

An ogee top shaped upright book with cord and tassel. This has hand carved roses on the left hand side of the book. The base has a shaped corner with a hole for a flower container.



CM60

An upright book with a hand carved design on the top of the headstone. The shaped base has a centre hole for a flower container.

Marble Lawn



CM61

A clipped corner headstone with incised carved ivy leaves on the top left corner. This sits on a base with a vase to the right.



CM62

A heart shaped headstone featuring carved wild roses. The shaped base has a centre hole for a flower container.



CM63

An oval shaped headstone with wild roses below the inscription area. This unique shaped base has a hole in each corner for a flower container.



CM64

A heart shaped headstone with curved shoulders. This has two incised carved roses in the panel. The base has a hole for a flower container in each corner.



CM65

A shaped headstone. The double rebates and the hand carved wild rose panel, together create an elegant memorial. This is sitting on a square shaped base.



CM66

Ogee shape headstone. This has hand carved wild roses in each shoulder. The shaped base has a centre hole for a flower container.



CM67

An ogee shape headstone with a classic hand carved rose panel. The base has a centre hole for a flower container.

The example above is shown in Dove Grey Marble.

Churchyard & Hand Carved



A range of carved memorials designed especially for churchyards. Deep carving shows off the natural beauty

CM68

A rustic shaped headstone with carved roses that are left un-highlighted. The base has a centre hole for a flower container.

Many Churchyards have strict rules and regulations that need to be adhered to including the material from which the memorial is made. All headstones in this section meet with that criteria.

All memorial designs are available in a range of colours and materials, see page 50 - 51 for further details.



CM69

A headstone which is ideal for a churchyard. This has an apex shape with scalloped corners. The base has a central flower hole for a container.

The example above is shown in Light Nabresina.



CM70

A rounded top headstone with checked corners. The base has a centre hole for a flower container.

The example above is shown in Sandstone.



CM71

Gothic top headstone with a circle of hand carved roses and leaves design.

The example above is shown in Light Nabresina.



CM72

Rounded top and ogee corners with a circle of hand carved roses on the top centre. This has a shaped base and a centre vase hole.

The example above is shown in Light Nabresina.



CM73

An arch top headstone with a raised panel and cross. The arch fronted base has a centre hole for a flower container.

The example above is shown in Sandstone.



CM74

A headstone with a rounded top and scalloped corners. This has a hand carved design in the centre of the headstone. The base is shaped and has a centre hole for a flower container.

The example above is shown in Light Nabresina.

Churchyard & Hand Carved



CM75

A traditional celtic wheel style cross headstone. The example is shown in Lunar Grey Granite.



CM76

A square shaped headstone with clipped corners. This fine, light grey granite is a perfect contrast to the dark highlighted margin pin line. The shaped base has a centre hole for a flower container. The example above is shown in Abbey Grey Granite.

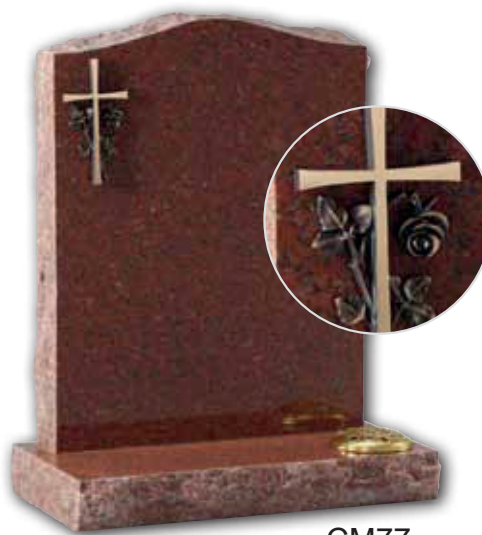

CM77

A headstone with a natural pitched edge. This has a bronze cross and rose design on the left hand side. The base has a hole on the right hand side for a flower container.

The example above is shown in Ruby Red Granite.



CM78

A traditional boulder style memorial. The base has a centre hole for a flower container.

The example above is shown in Celtic Grey Granite.



CM79

A gothic shaped headstone with natural rustic edges and rebate. The base has a centre hole for a flower container. The example above is shown in Balmoral Red Granite.



CM80

A rustic margin follows the check shaped shoulder of this headstone. The base has a centre hole for a flower container. The example above is shown in Dark Grey Granite.



CM81

A headstone with a natural rustic edge with matching margin. The base has a centre hole for a flower container. The example above is shown in Dark Grey Granite.



CM82

A rustic ogee shaped headstone with craftsman carved and highlighted roses either side of a latin cross. The base has a centre hole for a flower container. The example above is shown in Karin Grey Granite.



CM83

A rustic shaped headstone with coloured highlights which emphasise the spring daffodils. The base has a centre hole for a flower container. The example above is shown in Olive Granite.



CM84

A rustic headstone with hand carved daffodils which have a natural carved finish. The base has a centre hole for a flower container. The example above is shown in Olive Granite.

Churchyard & Hand Carved

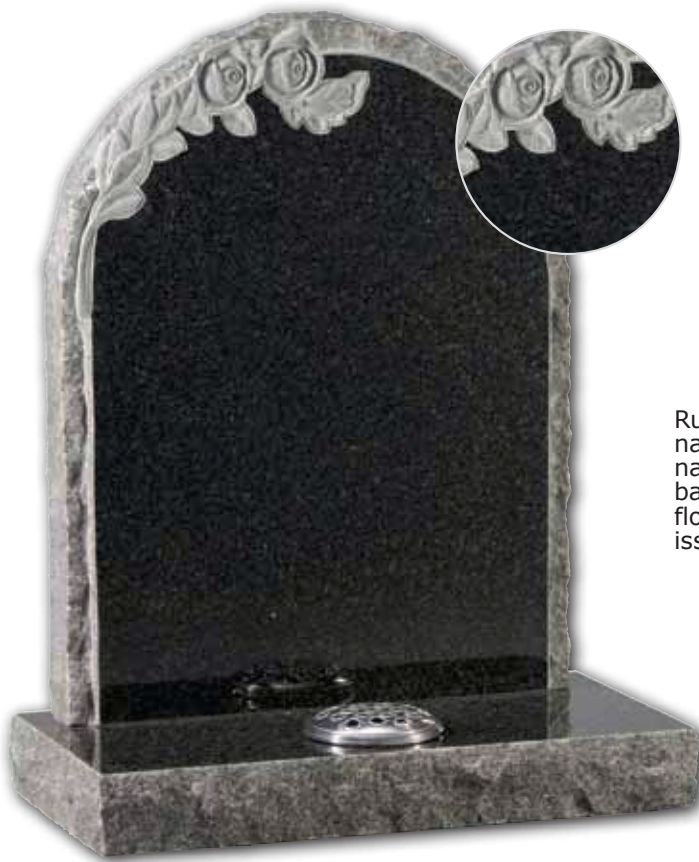

CM85

Rustic shaped headstone with natural carved roses and natural rock pitched edges. The base has a centre hole for a flower container. The example is shown in Dark Grey Granite.



CM86

A shaped headstone with hand carved roses which have been highlighted to contrast the natural rock pitched edge. The base has a corner hole for a flower container. The example above is shown in Dark Grey Granite.



CM87

An ogee shaped headstone with a relief carved and highlighted dove in the top centre. The base has a centre hole for a flower container. The example above is shown in Polished Karin Grey Granite.



CM88

A gothic shaped headstone with deep carved and highlighted roses. The base has a centre hole for a flower container. The example above is shown in Flint Grey Granite.



CM89

A magnificent carved angel sitting on a headstone. Size can be adapted to suit.



CM90

The pinnacle of the master carvers art, forms this beautiful mother and child figure. The base has pitched



CM91

A scroll shaped headstone with two hand carved angels either side of the scroll. The example above is



CM92

This headstone has rounded edges to give a cross effect memorial. The base has a centre hole for a flower container. The example



CM93

Natural rock pitched edges give a rustic look to this memorial. The base has a centre hole for a



CM94

A shaped headstone with rounded shoulders. This has a separate vase which sits in front of the base giving an optional place for flowers.

Churchyard designs



CM95

A headstone with a square top and check to the left hand side. This has a hand carved design on the left hand side of the headstone. The shaped base has a hole on the left for a flower container. The example above is shown in Light Nabresina.



CM96

This shaped yellow sandstone headstone has a natural pitched edge and margin. This has a sandblast cross design at the top of the memorial. The base has pitched edges. The example above is shown in Sandstone.



CM97

A shaped headstone which has a moulded profile around the edge. The base has a centre hole for a flower container. The example above is shown in Grey Sandstone.



CM98

A shaped headstone with natural pitched edges. It has a carved rose panel in the top centre. The base has natural pitched edges. The example above is shown in Light Nabresina.



CM99

An oval top headstone with shaping down each side. The example above is shown in Nabresina.



CM100

A peon top headstone with a hand carved rose and cross design. The example above is shown in Nabresina.



Nasby

A headstone with a shaped top and Axed and Punched edges. The shaped base has a hole on the left for a flower container. The example above is shown in Purbeck



Mowsley

This shaped yellow sandstone headstone has a natural pitched edge and margin. This has a sandblast cross design at the top of the memorial. The base has pitched edges. The example above is shown in Sandstone.



Saxby

A headstone with a shaped top and Axed and Punched edges. The shaped base has two holes on the for flower containers. The example above is shown in Purbeck



Badby

A Oval shaped headstone with a carved design panel in the top centre. The example above is shown in Light Nabresina.



Ashby

An OG top headstone with carved panel. The example above is shown in Nabresina.



Holdenby

A peon top headstone with a hand carved rose and cross design. It stands in the ground. Monolith type. Size: 4ft above ground. The example above is shown in Portland Stone.



CM101

This headstone has a triple rounded top which matches the front of the base. There is a carved rose at the top centre of the memorial. The example



CM102

A churchyard style memorial of the highest quality incorporating a hand carved daffodil. The example above is



CM103

A square top headstone with a dog rose in each corner. The base has a centre hole for a flower container.

Traditional Kerb Memorials

Consisting of a headstone and kerbed set, these memorials are only permitted in specific areas of the cemetery.

CM104

A book headstone with sand blasted ivy leaf design and a cord and tassel in gold leaf. This has kerbs and two front vase posts with a hole for a flower container. The example is shown in Polished Emerald Pearl Granite.



Kerbed memorials cover the entire grave. The interior of the memorial can be in-filled with top-soil or chippings. Alternatively, a cover slab can be placed within the kerbs.

All memorial designs are available in a range of colours and materials, see page 50 - 51 for further details.

CM105

A checked top headstone with two carved crosses. This has kerbs and checked posts with a chamfered foot kerb which is ideal for an inscription. The example is shown in Marble.



CM106

A shaped headstone with a church window design each side. This has side kerbs and front posts which can have holes in for flower containers. The example is shown in Marble.



CM107

A bible book headstone with a carved cord and tassel. This is sitting on a kerb surround with corner posts and a vase in the centre for flowers.



CM108

A headstone with scalloped corners and hand carved roses. This has kerbs and two front posts. The chamfered foot kerb is ideal for an inscription.



CM109

A headstone with a sculptured angel and carved letters which say the word 'Peace'. The kerbs are chamfered and there are three posts. The centre has a hole for a flower container and there is a carved rose on the post.



CM110

A traditional memorial with a cross at the head part that sits on a block with shaped fillers. At the bottom of the memorial sits a book with a cord and tassel. There are two vase posts with a hole for a flower container.



Traditional Kerbed Memorials

CM111

An upright book headstone with hand carved roses. This has kerbs and two posts. A marble bowl vase sits in the centre of the memorial. The example is shown in Marble.

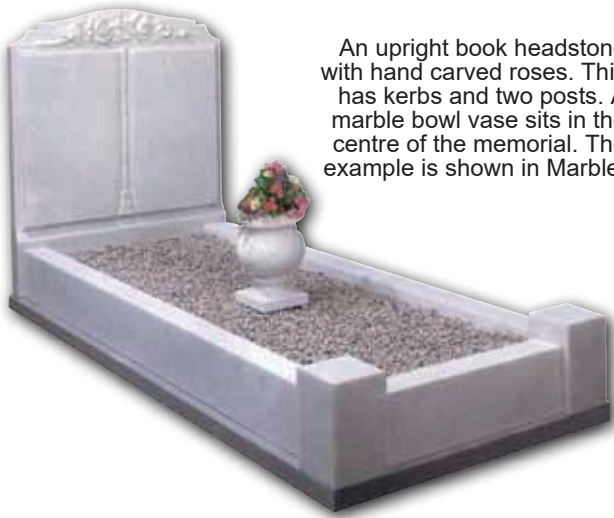

CM112

This has a vase post at the head of the memorial. There are two centre posts and four side kerbs with an inscription panel at the front.



CM113

A book bible headstone with a carved cord and tassel which is sitting on two rests. This has side kerbs and a front centre vase post which has a hole for a flower container. The example is shown in Polished Lunar Grey Granite.



CM114

A headstone with hand carved roses and cross. This has a full kerb surround with one corner vase post. The example is shown in Marble.



CM115

A rounded shaped headstone with a shaded heart and coloured rose design. This has kerbs and two posts. The example is shown



CM116

A square shaped headstone with a design to the left. This has a plain kerb surround. The example is shown in Polished Black Granite.



CM117

A headstone with a sandblasted book and rose design. This has kerbs, two posts and a central vase post which has a hole for a flower container. The example is shown in Polished Black Granite.



CM118

A classic ogee headstone. There are kerbs and two posts which can be bored for a flower container. A vase sits in the centre of the memorial. The example is shown in Polished Black Granite.



CM119

A shaped headstone with a highlighted ribbon and wild flower design. This has kerbs and two posts with a hole for a flower container at the front of the memorial. The example is shown in Avon Grey Granite.



CM120

This memorial has four kerbs and attractive peon top posts. There is room on the chamfer of the kerb for an inscription. The example is shown in Autumn Brown Granite.

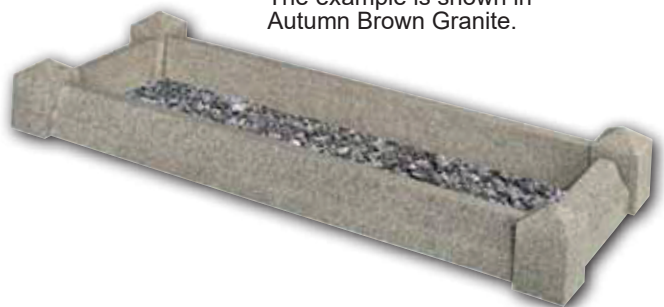

CM121

This headstone has checked corners and a bronze cross at the top. There are kerbs and two end posts. A double vase sits in the centre. The example is shown in Balmoral Red Granite.

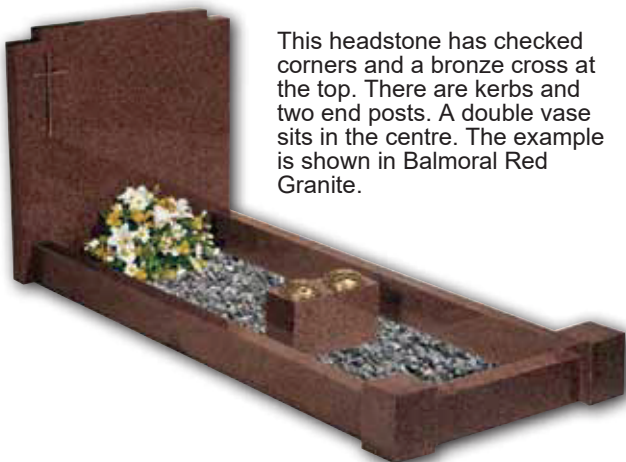

CM122

A heart headstone with a sandblasted design on the shoulders. This has a chamfered kerb surround and two front vase posts with a hole for a flower container. The example is shown in Polished Red Balmoral.



CM123

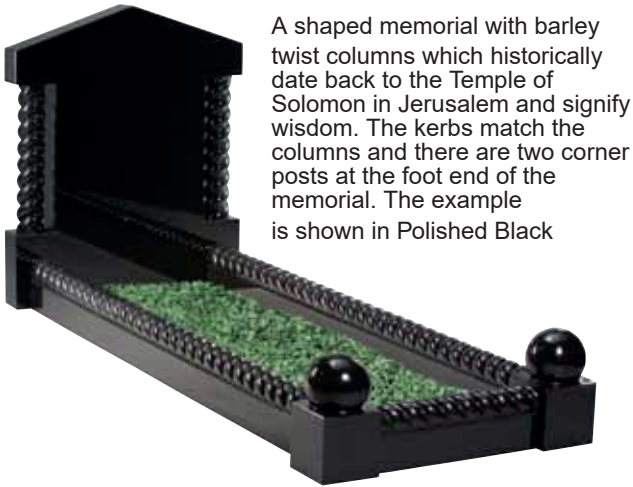

A shaped memorial with barley twist columns which historically date back to the Temple of Solomon in Jerusalem and signify wisdom. The kerbs match the columns and there are two corner posts at the foot end of the memorial. The example is shown in Polished Black

CM124

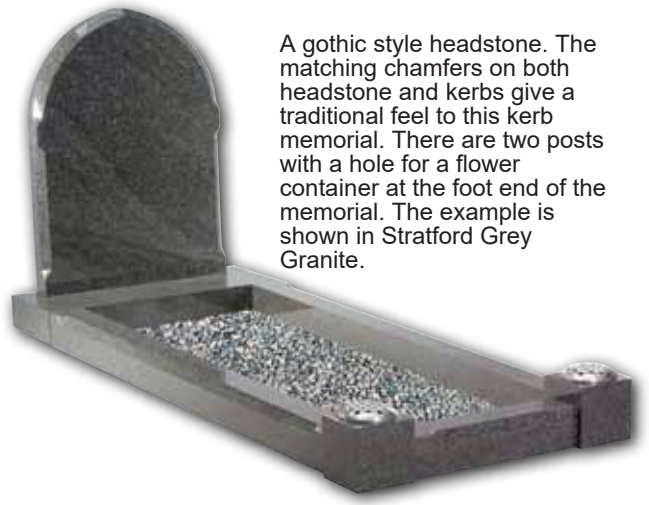

A gothic style headstone. The matching chamfers on both headstone and kerbs give a traditional feel to this kerb memorial. There are two posts with a hole for a flower container at the foot end of the memorial. The example is shown in Stratford Grey Granite.

CM125



A shaped headstone with a heart cutout in the top centre which allows the placing of a marble dove. There are kerbs and two end posts with a hole for a flower container. The example is shown in Polished Black Granite.

CM126



This kerb memorial incorporates a vase at the head end and a tablet at the foot allowing for an inscription. The example is shown in Polished Lunar Grey Granite.

CM127

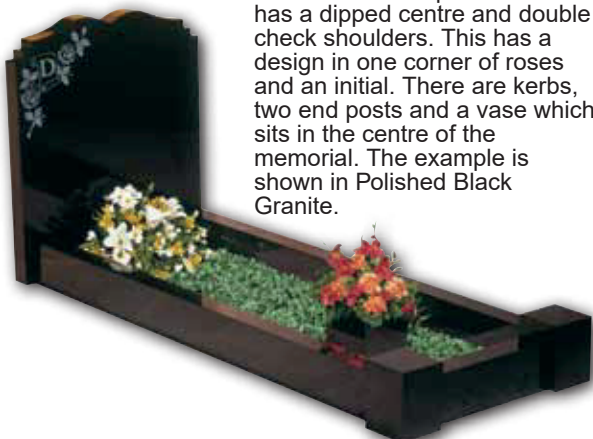

This unusual shaped headstone has a dipped centre and double check shoulders. This has a design in one corner of roses and an initial. There are kerbs, two end posts and a vase which sits in the centre of the memorial. The example is shown in Polished Black Granite.

CM128



All Polished Blue Pearl Granite.



Traditional Kerbed Memorials

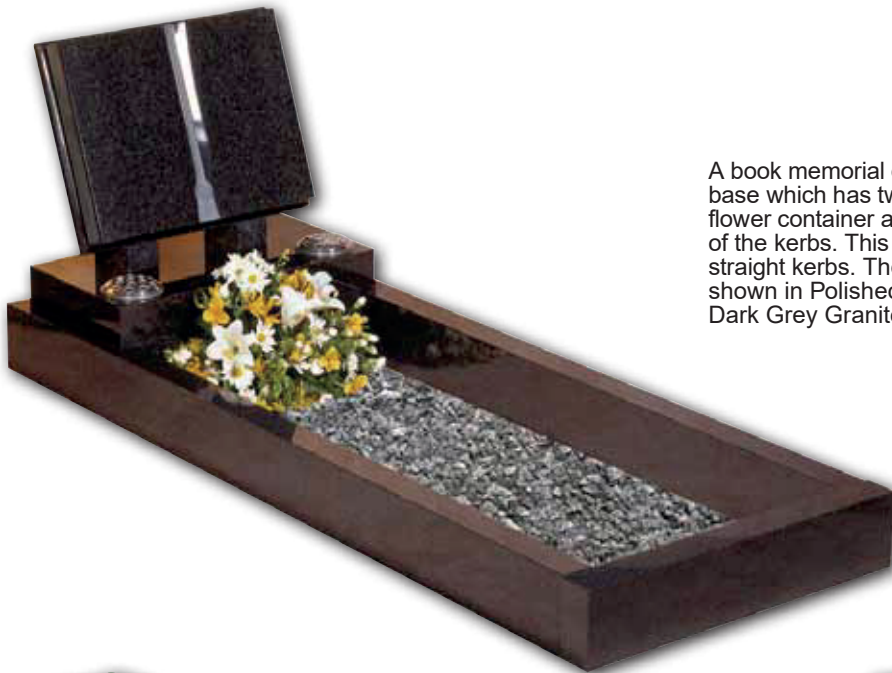

CM129

A book memorial on top of a base which has two holes for a flower container and sits on top of the kerbs. This has four straight kerbs. The example is shown in Polished Rustenburg Dark Grey Granite.



CM130

Ogee headstone with marble steps and winding pathway. There are three holes for flower containers and chippings the colour of your choice (design on headstone not included in price). The example is shown in Polished Black Granite.

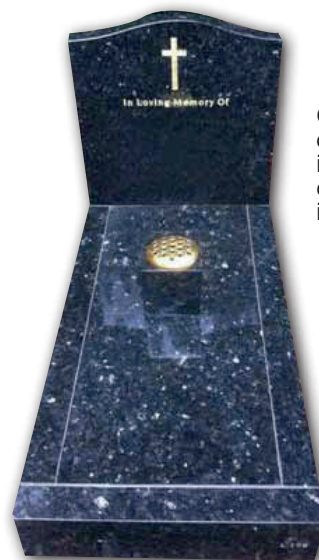

CM131

Ogee headstone with cross design, straight kerbs and internal cover-slab with vase to centre. The example is shown in Polished Blue Pearl Granite.



CM132

Gates of Heaven headstone with steps and a centre winding path leading to steps. A shaped book with cord and tassel rests elegantly on the steps. There are two holes for flower containers, and chippings the colour of your choice (photo plaque not included in price). The example is shown in Polished Bahama Blue Granite.

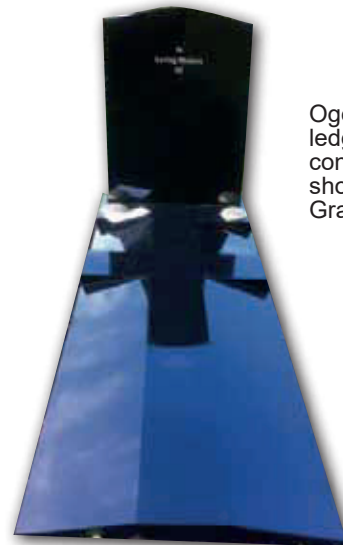

CM133

Ogee headstone with shaped ledge and two holes for flower containers. The example is shown in Polished Black Granite.



CM134

With two raised hearts, internal cover-slab which leads to a shaped book with cord and tassel which rests elegantly on steps. There are three holes for flower containers (photo plaque not included in price). The example is shown in Polished Black Granite.

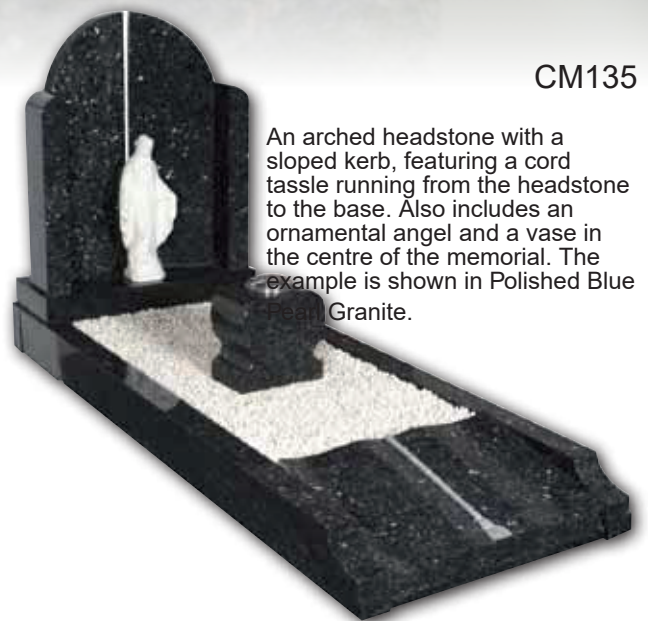

CM135

An arched headstone with a sloped kerb, featuring a cord tassel running from the headstone to the base. Also includes an ornamental angel and a vase in the centre of the memorial. The example is shown in Polished Blue Pearl Granite.

CM136

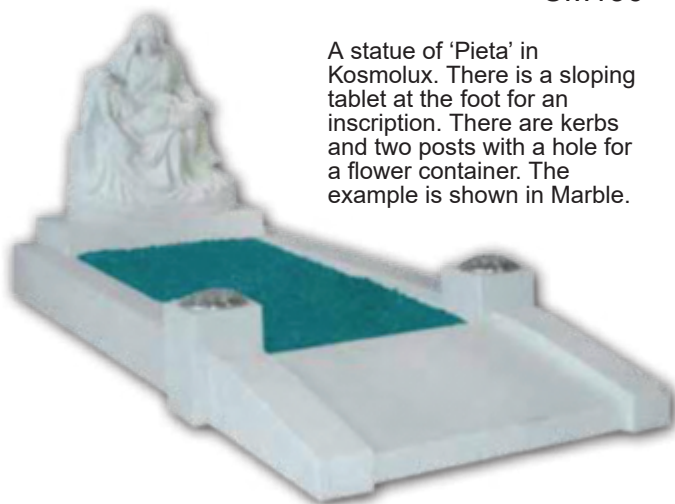

A statue of 'Pieta' in Kosmolux. There is a sloping tablet at the foot for an inscription. There are kerbs and two posts with a hole for a flower container. The example is shown in Marble.



CM137

A heart shaped headstone on a sloping kerbed base with cover-slab. The example is shown in Polished Tropical Green Granite.

Children's Memorials

These memorials are designed specifically to meet the cemetery authority's criteria for the children's section of a cemetery.



CM138

This slightly smaller heart headstone with hand carved angel is also suitable for a cremation plot. The base has a centre hole for a flower container. The example is shown in Polished Blue Pearl Granite.

This section shows just some of the memorials available for placement within the children's section of a cemetery. Other designs are available on request.

All memorial designs are available in a range of colours and materials, see page 50 - 51 for further details.



CM139

A square shape headstone with a sandblast coloured design. This is sitting on a base with a vase which has a hole for a flower container. The example above is shown in Polished Black Granite.



CM140

An arch top headstone with a sandblast design. This sits on a base with a vase which has a hole for a flower container. The example above is shown in Polished Black Granite.



CM141

A square top headstone with sloping corners. This has a sandblast coloured design and sits on the base with a vase which has a hole for a flower container. The example above is shown in Polished Black Granite.



CM142

A shaped heart headstone with a hand carved design each side of the heart. This sits on a base which has a centre hole for a flower container. The example above is shown in Marble.



CM143

An angel over shaped book design headstone. This is sitting on a base next to a vase which has a hole for a flower container. The above example is shown in Marble.



CM144

A headstone shaped as a Teddy Bear which sits on a base. The base has a hole on the left hand side which is for a flower container. The example above is shown in Marble.

Children's Memorials

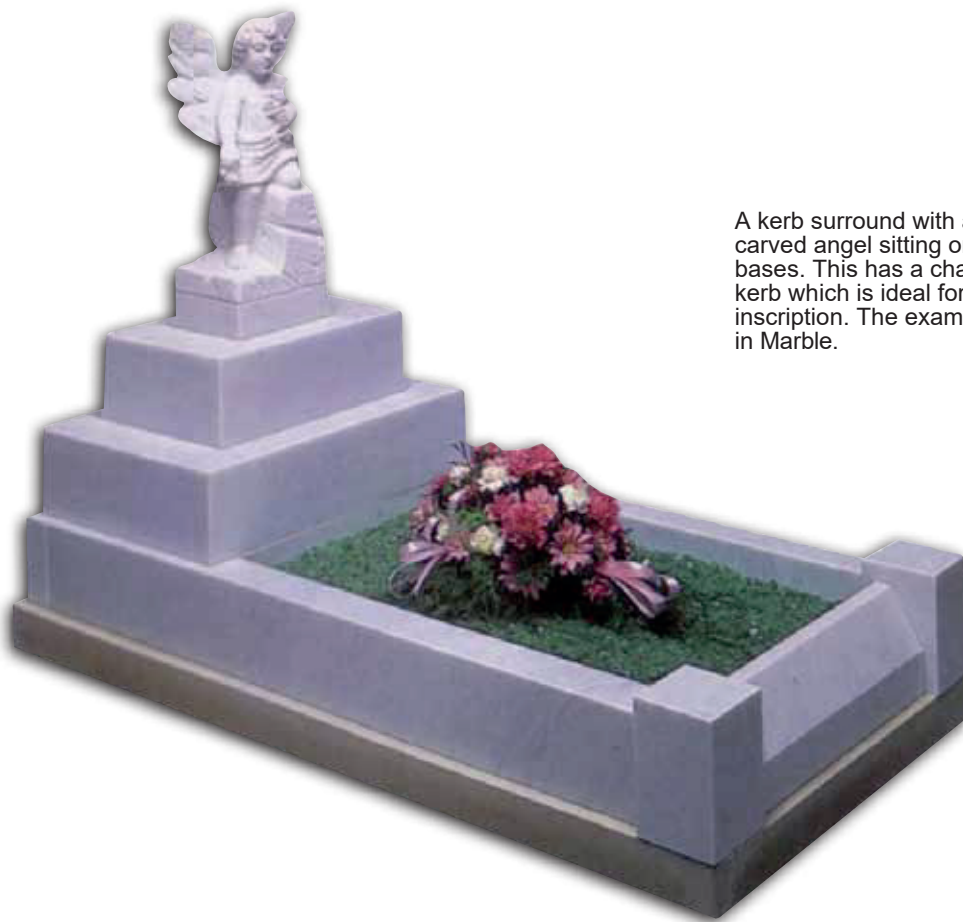

CM145

A kerb surround with a hand carved angel sitting on two die bases. This has a chamfered foot kerb which is ideal for an inscription. The example is shown in Marble.



CM146

A highlighted teddy bear cuddles the inscription area of this headstone. The base has a hole for a flower container. The example above is shown in Polished Imperial Red Granite.



CM147

A child's teddy headstone which sits on a base with a centre hole for a flower container. The example above is shown in Polished Blue Pearl Granite.



CM148

A shaped headstone with a painted rabbit design. This is sitting on a base which has a hole on the right hand side for a flower container. The example above is shown in Polished Black Granite.



CM149

Half ogee shape headstone with a personalised highlighted design. The base has a hole on the right hand side for a flower container. The example above is shown in Polished Dark Grey Granite.



CM150

An ogee shape headstone with a scarf design at the top. This sits on a base with a football 9" diameter and is made of Black and Rose White Granite. Any team or sport can be represented. The example above is shown in Polished Black Granite.



CM151

A rounded top headstone with shaped shoulders. This has a moon and baby design and is sitting on a base which has a centre hole for a flower container. The baby grow can also be painted pink or blue. The example above is shown in Polished Black Granite.

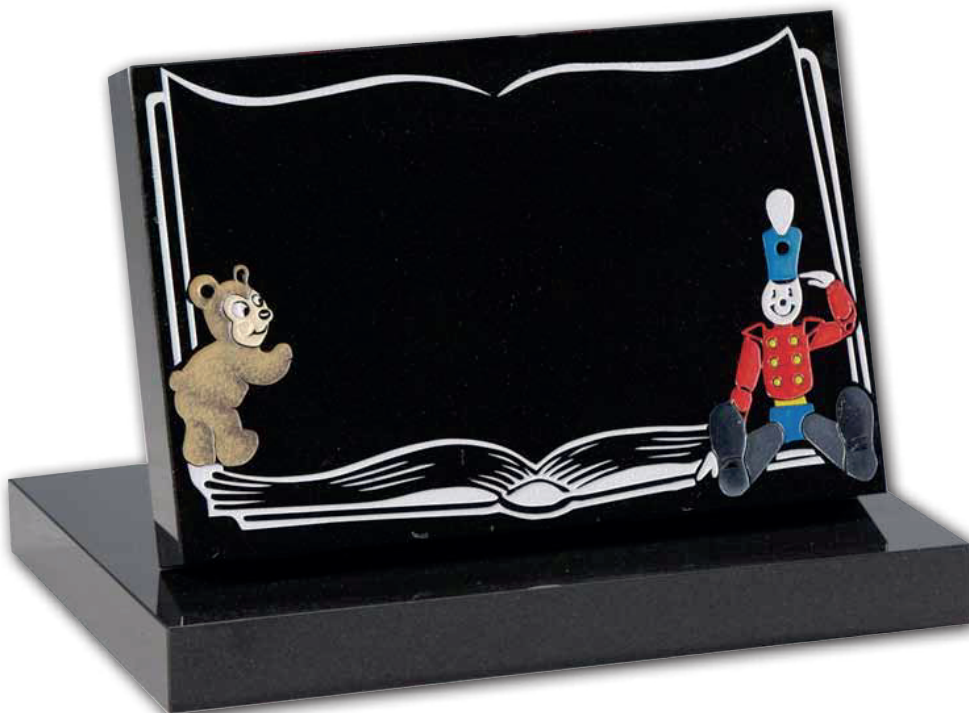

CM152

A tablet headstone sitting on a base which has a vase in the rest. The face of the memorial features a sandblast book design incorporating a bear and soldier design. Any favourite character can be added. The example is shown in Polished Black Granite.

Cremation Memorials

A range of memorials designed specifically for ashes plots within a cemetery.



CM153

A small cremation book with a cord and tassel. This is sitting on a base with a side vase. The example above is

A wide range of designs are shown and their dimensions can be altered to meet the particular requirements of the crematorium garden, cemetery or churchyard. Churchyards, cemeteries and crematoria gardens have varying criteria for these memorials. We can manufacture the memorials in this section to meet those needs. Our advisors would be pleased to assist you in establishing what they are.

All memorial designs are available in a range of colours and materials, see page 50 - 51 for further details.



AK154

An ogee shape headstone sitting on a sloping desk tablet. There is a centre hole in the top of the desk tablet for a flower container. The example above is shown in Polished Blue Pearl Granite.



CM155

A half ogee shape headstone with a sandblast Madonna colour design. This is sitting on a base with mini side kerbs and two vase posts which have a hole for a flower container. The example above is shown in Polished Blue Pearl Granite.



CM156

An ogee shaped headstone with rope effect around the edges. This has a kerb extension from the base which matches the headstone. The base has a centre hole for a flower container. The example above is shown in Polished Black Granite.



CM157

This cremation memorial features an oval top headstone. This is sitting on a base with a hole on the right hand side for a flower container. The example above is shown in Polished Ruby Red Granite.



CM158

An ogee shape memorial designed for a cremation plot. This is sitting on a base which has a hole on the right hand side for a flower container. The example above is shown in Polished Coral Green Granite.



CM159

This simple cremation tablet features one of a range of designs that can be added. This is sitting on a base next to a vase. The example above is shown in Polished Black Granite.

Cremation Memorials



CM160

An historical celtic wheel cross and celtic design headstone. This has a bronze bird on each side of the inscription area. The base has two holes for a flower container. The example above is shown in Polished Dark Grey Granite.



CM161

A small heart and rest which sits on a base next to a vase. The example above is shown in Polished Dark Grey Granite.



CM162

A tablet sitting on the front of the base. The rest for the tablet can be used as a vase for flowers. The example above is shown in Polished Lunar Grey Granite.

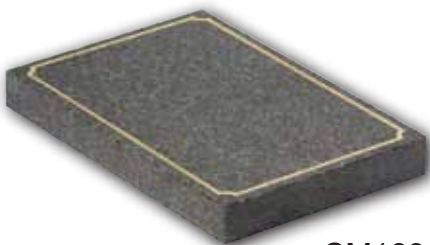

CM163

A cremation tablet featuring a gilded pin line with shaping in each corner. The example above is shown in Polished Dark Grey Granite.

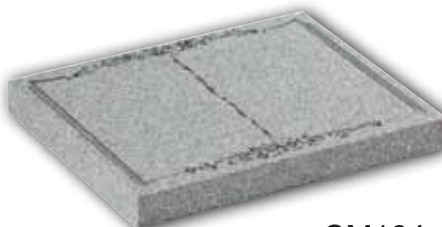

CM164

A cremation tablet featuring a delicate book and flower design. The example above is shown in Polished Lunar Grey Granite.



CM165

A cremation tablet with an elegant pin line and corner sandblast coloured rose. The example above is shown in



CM166

An oval shaped headstone which sits behind a desk tablet. This has a hole for a flower container. The example above is shown in Polished Dark Grey

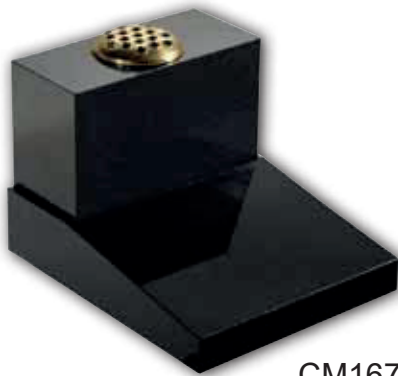

CM167

A desk tablet with a vase sitting on the flat of the desk. This is ideal for two inscriptions. The example above is shown in Polished Black Granite.



CM168

A scroll shaped cremation memorial. This example above is shown in Polished Black Granite.



CM169

A desk tablet with an elegant moulded edge. This has a centre hole at the top for a flower container. The example above is shown in Polished Black Granite.



CM170

A cremation desk tablet featuring a sandblast rose design on the left and on the right a hole for a flower container. The example above is shown in Polished Black Granite.



CM171

A desk tablet with a book design which is sandblasted and highlighted. There is a hole for a flower container at the top centre of the tablet. The example above is shown in Polished Glenaby Granite.



CM172

This cremation memorial has a worked book and a carved cord and tassel. The top flat band is bored for a flower container. The example above is shown in Polished Black Granite.



CM173

A worked book on the face of this cremation sized memorial. The example above is shown in Polished Tropical Green Granite.



CM174

A scroll shaped book tablet with a carved and highlighted rose. The example above is shown in Polished Black Granite.



HAYFORD

A desk tablet the flat of the desk. This is ideal for two inscriptions. The example above is shown in Polished Black Granite. With a rose design.



HIGHAM

A tablet to lay flat. It has rustic edges. This can be in any stone.

The example is shown in Purbeck.



OAKHAM

A cremation desk tablet. 18inch square.

The example above is shown in Nabresina.

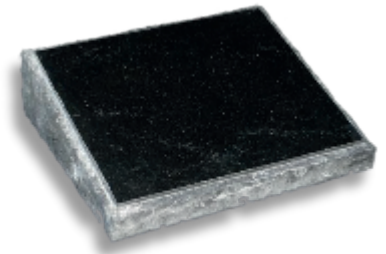

KIRDFORD

A desk tablet the flat of the desk. This is ideal for two inscriptions.

The example above is shown in Polished Star Galaxy Granite. With axed edges.



EYEDON

This cremation memorial has a worked pillow.

The example is shown in White Marble.

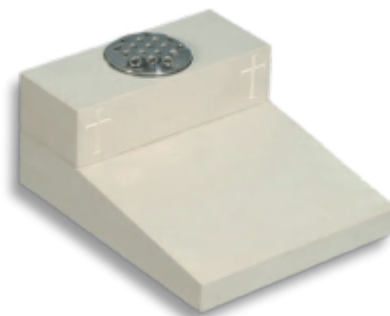

HINTON

A cremation desk tablet.

The example above is shown in Nabresina.



ADSTONE

A cremation desk tablet.

The example above is shown in Light Grey Granite.

Vases

Marble and granite vases can be added to any of the memorials shown in this brochure.



AK175

A vase with carved daffodil.

The example is shown in
Marble.

Vases are a popular addition to a memorial providing an everlasting container for placing flowers. They can also be purchased as a memorial in their own right.



CM176

A vase with a checked top and centre. The example above is shown in



CM177

A bowl vase. The example above is shown in Marble.



CM178

A vase with a hand carved rose and a raised panel for an inscription. The example above is shown in Marble.



CM179

A vase with a hand carved rose in the sunken panel. This also has a checked top. The example above is shown in Marble.



CM180

A vase with a raised panel. The example above is shown in Marble.



CM181

A vase with a hand carved daffodil. The



CM182

A vase with a hand carved rose and raised cross design. The example above is shown in Marble.

CM183

A vase with two hand carved daffodils, one each side of the raised panel. The



Vases



AK185

Rather than the simple square vase this has the corners chamfered and a cut around the top. The example above is



AK184

A Vase. The example above is shown



AK186

This flower vase has been worked into the shape of a heart. The example above is shown in polished Black



AK187

A bowl vase. The example above is

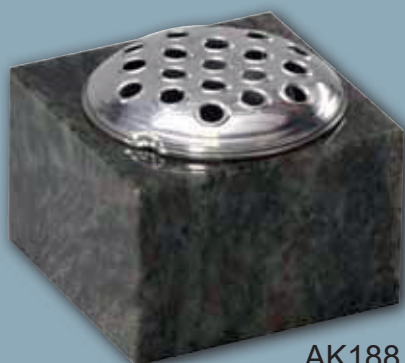

AK188

A small vase. The example above is shown in polished Tropical Green Granite.



AK189

A double vase with a photographic etched portrait. Your own photo can be accurately reproduced. The example above is shown in polished Black Granite.

Memorial Renovation



Over time the traditional porous materials used for memorials can be effected by the weather. The once beautiful stone can become stained and dirty, the inscription worn and illegible. In our hands we can restore this to its former glory.

By carefully and sympathetically cleaning the memorial stone, re-gilding the lettering and re-fixing it using modern anchoring techniques, we can reinstate it close to its original condition. There are rare occasions where the memorial is in such a poor state of repair that it will prove too expensive to renovate. In this case we will offer guidance on the alternatives available.

Please contact us for a free, no-obligation quote. We can usually provide this from photographs.



Etching

Always popular, here is a small sample of the endless variety of flowers, plants and religious symbols that can be added to your memorial, or their images such as sporting motifs, military emblems and personal logos can be etched onto the granite surface.

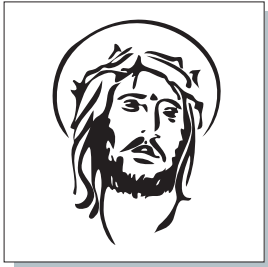

D0



D0



D0



D0



D0



D0

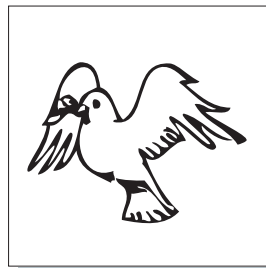

D07

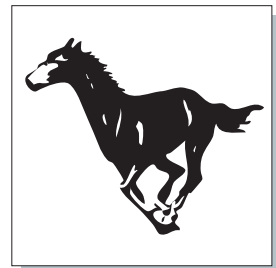

D08



D0



D1

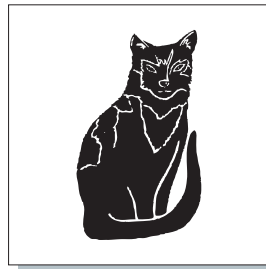

D11



D12



D1

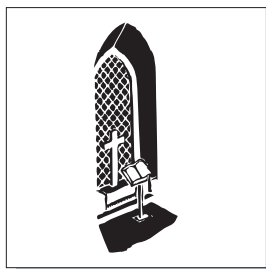

D1

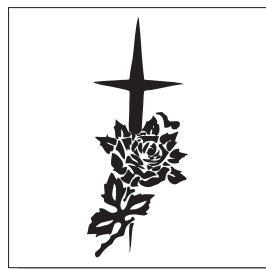

D1



D1



D1

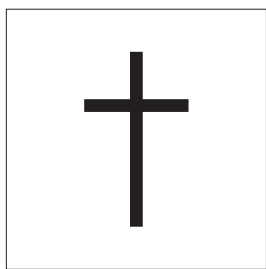

D1

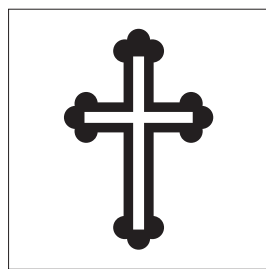

D1



D2

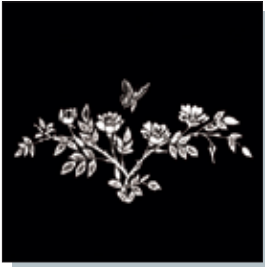

D2



D2



D2



D2

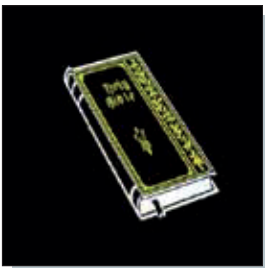

D25

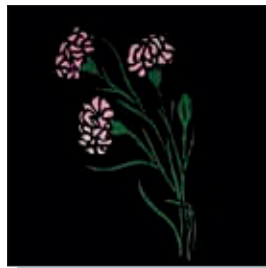

D26



D27

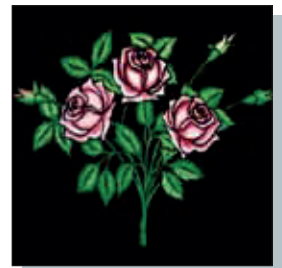

D29



D3



D31



D32



D33

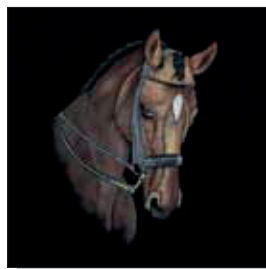

D3



D3



D36

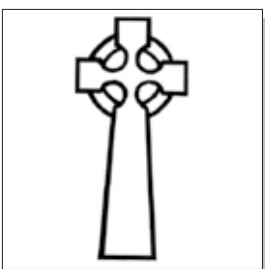

D37



D38



D3



D4

Material Sample Guide



The colour chart below provides an indication of the colour and shading of the various granite, natural stones and granite chipping infill's available. It is important to note that the samples shown below are a guide only. All materials used are of

Granite

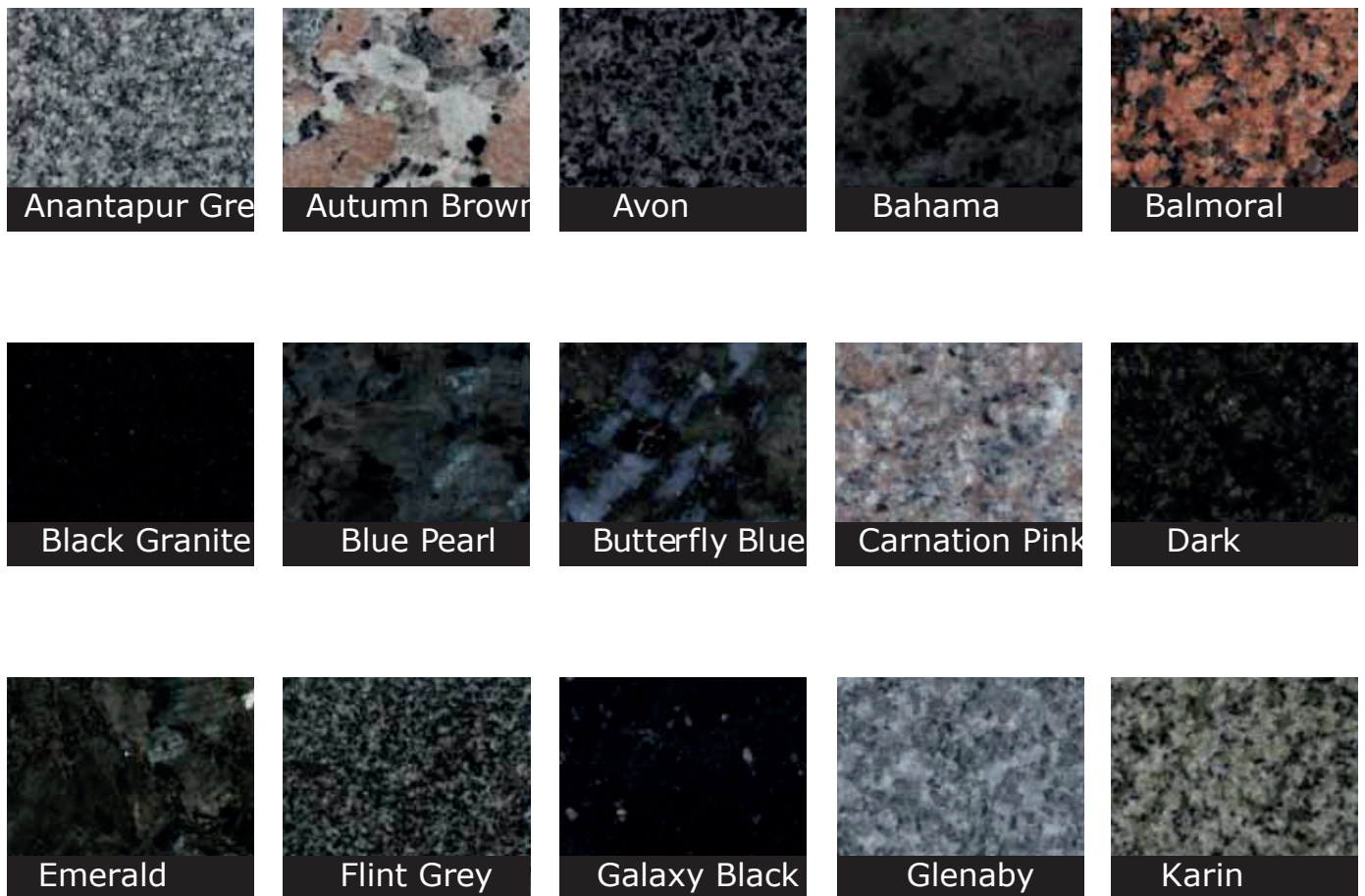

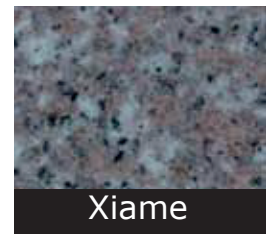
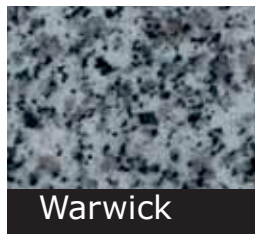
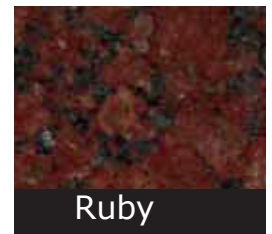
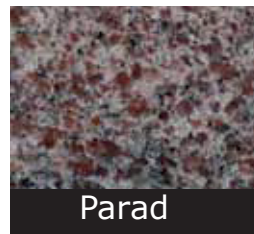
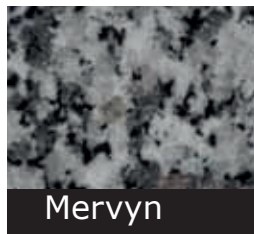
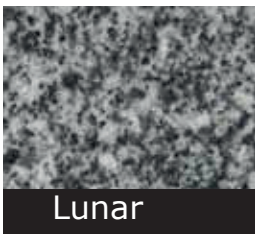

Natural Stone

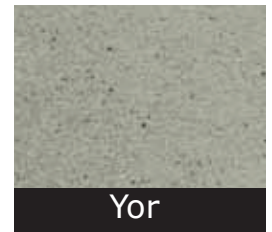
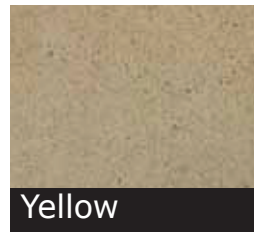
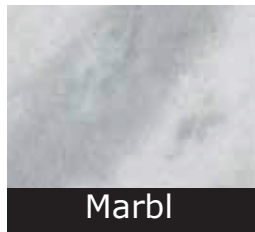
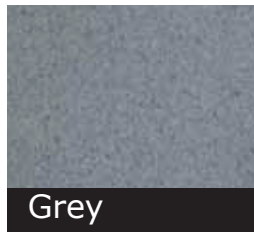

Chipping

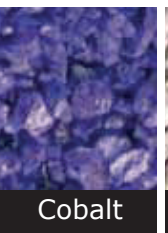
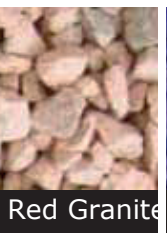
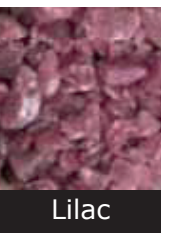
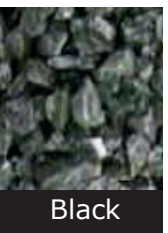
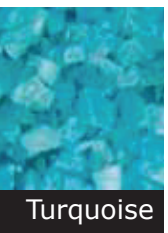
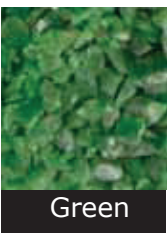

Specially Commissioned Memorials



A memorial is the commemoration of a person's life, it is the most challenging dedication to create. The memorials in this brochure are designed to meet the needs of most people but we realise they won't meet everybody's. We are therefore pleased to offer a design service to match any memorial you may have seen or to create something unique.

An example of headstone design and specification

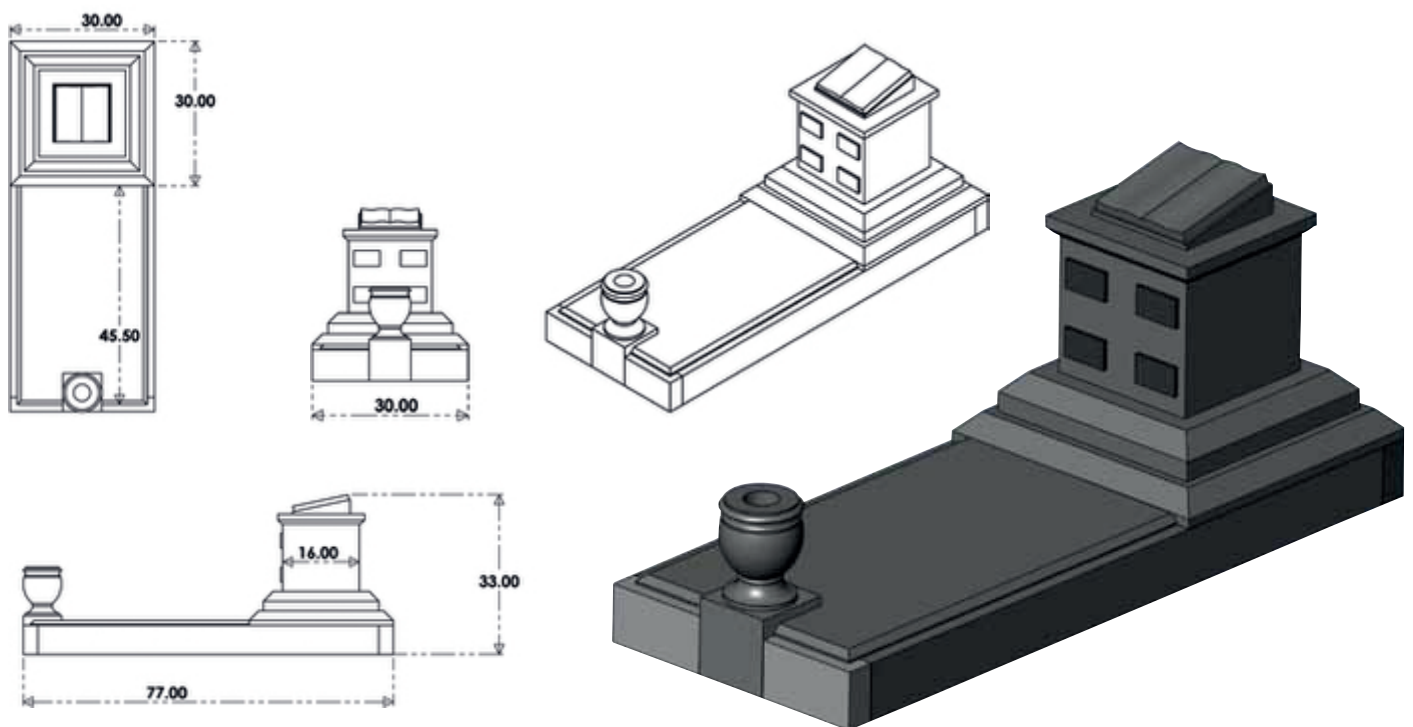

A guide to our Free No-obligation service



- An initial consultation with one of our memorial advisors will help us to understand your needs and allow us to start the process of creating your memorial.
- We will liaise with the burial authority, churchyard or cemetery to confirm that your chosen memorial design meets with their regulations. once everything is agreed we will provide you with a no-obligation estimate.
- On acceptance of this, we will produce the design specification drawings for you to review and approve.



- Our skilled craftsmen will then start the process of creating your memorial. We apply quality control measures throughout the process; from the purchase of the raw materials, through the manufacturing and design process to the final fixing in the cemetery, every stage is checked and double checked before being allowed to proceed to the next.
- We employ highly skilled craftsmen who combine traditional masonry skills with the factory's computer technologies to ensure we deliver memorials of the highest quality and standard.

Please call us on **01483 273770**

Inscription Examples

The content of inscriptions is very personal. Memorials should celebrate and honour life. We have provided some examples of styles, language and fonts to help you choose a fitting inscription.

Example 'A' in Modern Block

IN LOVING MEMORY OF
A DEAR HUSBAND AND FATHER
NAME ...
WHO DIED INSERT DATE HERE
AGED XX YEARS ALWAYS IN OUR
THOUGHTS FOREVER IN OUR

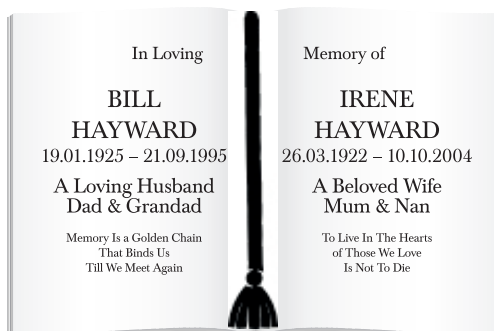

Example 'A' in Times New Roman

IN LOVING MEMORY OF
A DEAR HUSBAND AND FATHER
NAME ...
WHO DIED INSERT DATE HERE
AGED XX YEARS ALWAYS IN OUR
THOUGHTS FOREVER IN OUR HEARTS

All our inscriptions can be produced using the following typefaces.

Times New Roman

abcdefghijklmnopqrstuvwxy
z
ABc DEFGHIj k LMNOp q RSTUVWXYz
0123456789

Novarese Bold

abcdefghijklmnopqrstuvwxy
z
ABCDEFGHIJKLMN**OP**QRSTU**VW**XYZ
0123456789

Modern Block - Arial Black

abcdefghijklmnopqrstuvwxy
z
ABc d e f g h i j k l M n o p q r s t u v w x y z
0123456789

Coventry Script

abcdefghijklmnopqrstuvwxy
z
ABCDEFGHIJKL**MNO** **PQR** **STUV** **WXYZ**
0123456789

Times Bold

abcdefghijklmnopqrstuvwxy
z
ABCDEFGHIJKLMN**OP**QRSTU**VW**XYZ
0123456789

Zaph Chancery Bold

abcdefghijklmnopqrstuvwxy
z
ABCDEFGHIJKLMN**OP**QRSTU**VW**XYZ
0123456789

Verse Examples

AKM 01

GOD SEES WHEN THE FOOTSTEPS FALTER
WHEN THE PATHWAY HAS GROWN TOO
STEEP SO HE TOUCHES THE DROOPING
EYELIDS AND GIVETH HIS LOVED ONE SLEEP

AKM 05

HE WAS THE FATHER SO VERY RARE,
CONTENT IN HOME AND ALWAYS THERE,
UNSELFISH WAYS AND A HEART OF GOLD,
NO FINER FATHER THIS WORLD COULD HOLD

AKM 09

GONE ARE THE DAYS
WE USED TO SHARE
BUT IN OUR HEARTS
YOU'RE ALWAYS THERE

AKM 02

ALWAYS IN OUR THOUGHTS
FOREVER IN OUR HEARTS

AKM 06

PEACE PERFECT PEACE

AKM 10

TOO DEARLY LOVED TO BE FORGOTTEN

AKM 03

MY THOUGHTS OF THEE WILL NEVER FADE
AND TIME WILL NEVER STEAL
THY SWEET SELF FROM MY HEART

AKM 07

HIS LIFE A BEAUTIFUL MEMORY
HIS ABSENCE A SILENT GRIEF

AKM 11

IT BROKE OUR HEARTS TO LOSE YOU
BUT YOU DID NOT GO ALONE
FOR PART OF US WENT WITH YOU
THE DAY GOD CALLED YOU HOME

AKM 04

TO LIVE IN THE HEARTS OF THOSE WE LOVE
IS NOT TO DIE

AKM 08

LOVING AND KIND IN ALL HIS WAYS
UPRIGHT AND JUST TO THE END OF HIS
DAYS
SINCERE AND TRUE IN HEART AND MIND
A BEAUTIFUL MEMORY LEFT BEHIND



Legal

A permit application must be submitted to the Cemetery/Churchyard before a memorial can be erected. There is normally a charge for this and our Sales Advisor will make enquiries on your behalf as to what these fees are.

We will provide this service for you by obtaining the form and completing it. This should be checked and MUST be signed by the

Churchyard Rules and

Materials

All memorials must be made out of natural stone with no reflecting finish, or of hardwood. Stones traditionally used in local buildings, or stones closely similar to them in colour and texture, are to be preferred. Black, green, blue or red granite are not permitted under these terms and conditions nor granite darker than Rustenburg grey, no black nor white marble, synthetic stone or plastic.

Designs

Headstones need not be restricted to a rectangular shape, and curved tops are preferable to straight-edged tops. Memorials in the shape of a heart or book are not permitted, nor are photographs, portraits, kerbs, railings, chains, chippings or glass shades. The headstone must not exceed 107cm (3ft 6in) in height measured from the surface of the ground, 76cm (2ft 6in) in width and

Payment Terms and

When placing an order we require 75% deposit plus payment in full for the Cemetery/Churchyard application fees.

The final balance is to be paid in full when the memorial is ready to be fixed at the Cemetery (approx 2-4 weeks before completion).

Or

Payment in full upon placing the order.

Flowers and Vases

Except where the design of a headstone includes an integral receptacle, any flowers must be placed in a removable container sunk completely into the ground. Small stone vases not exceeding 300mm (12in) x 200mm (8in) x 200mm (8in) may be permitted. The use of plastic and other artificial flowers is not permitted.

Commemoration after cremation and burial of ashes
Individual memorial stones are allowed: they should be of standard material, size and design. Such memorials may be erected vertically or horizontally and must not exceed 520mm (21in) x 520mm (21in).
The total surface of the stone must be level and flush with the ground.

The Parochial Church Council may level any grave mound at its discretion at any more than twelve months after the latest interment in the grave.

Prior to any headstone being erected, the person responsible for

Cranleigh Memorials

Sussex House
Ewhurst Road
Cranleigh
Surrey GU6 7AE

www.cranleighmemorials.com

admin@scancad.co.uk

Tel: 01483 273770

